

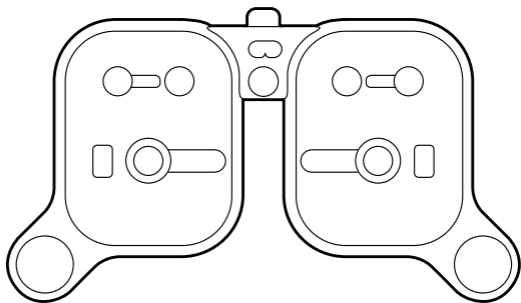

EYENETRA

NETROPTER v1.01

User Manual



INDICATIONS AND INTENDED USE STATEMENT

The Netropter is intended for use by either a Visioneer or optometric/ophthalmic professional to provide a means of positioning spherical and cylindrical lenses in front of a subject's eyes for purpose of determining refractive error and binocular functions such as visual acuity (both near and far). The Netropter is intended to replace traditional phoropters and trial lens kits as currently used in EyeNetra's service offering.

Carefully remove the contents from the package. If anything is missing or damaged, please visit our customer support website at store.eyenetra.com or call **Monday** thru **Friday** 9:00 AM - 5:00 PM (EST) +1 (857) 997 2057

If you purchased from an authorized re-seller, please contact them directly.

Please review the contents of this manual carefully before setting up or operating the device. For more information, visit our website: www.eyenetra.com

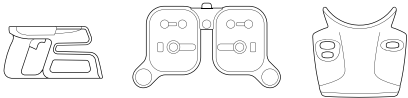

SMARTPHONE-POWERED REFRACTION

For Mobile Clinics | For Optical Shops | For Existing Practices

THE NETROPTER DEVICE IS NOT MADE WITH NATURAL RUBBER LATEX

The following items are included in this kit:

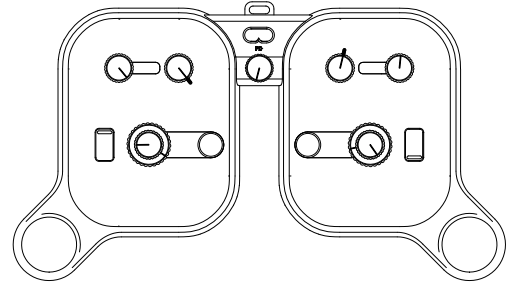

NETROPTER



MICROFIBER CLOTH

TABLE OF CONTENTS

Your NETROPTER	5
Use	9
Technical Specifications	17
FAQ	19
Warranty and Support	21
Terms of Sale	25
Refund Policy	29

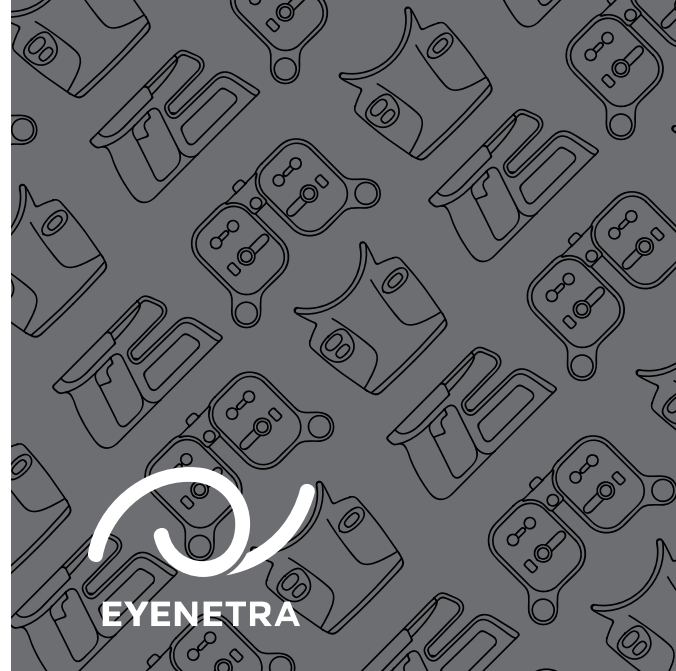

NETROPTER

Your NETROPTER

FRONT VIEW

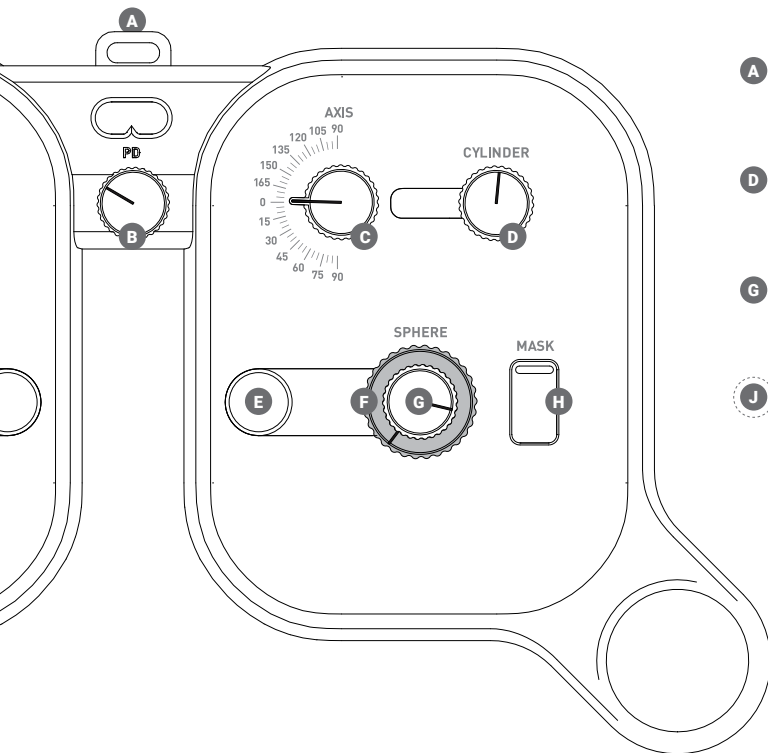

- A** PD Lock
- B** PD Knob
- C** Axis Knob
- D** Cylinder Knob
- E** Aperture
- F** Minor Sphere Knob
- G** Major Sphere Knob
- H** Occluder Switch
- I** OD (patient's right eye)
- J** OS (patient's left eye)

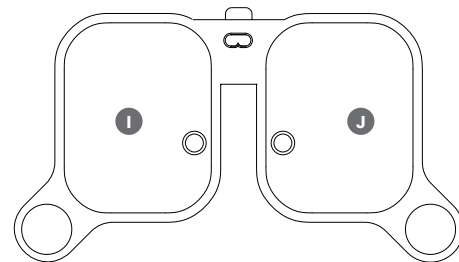

BACK VIEW

K Thumb Rest

L Aperture

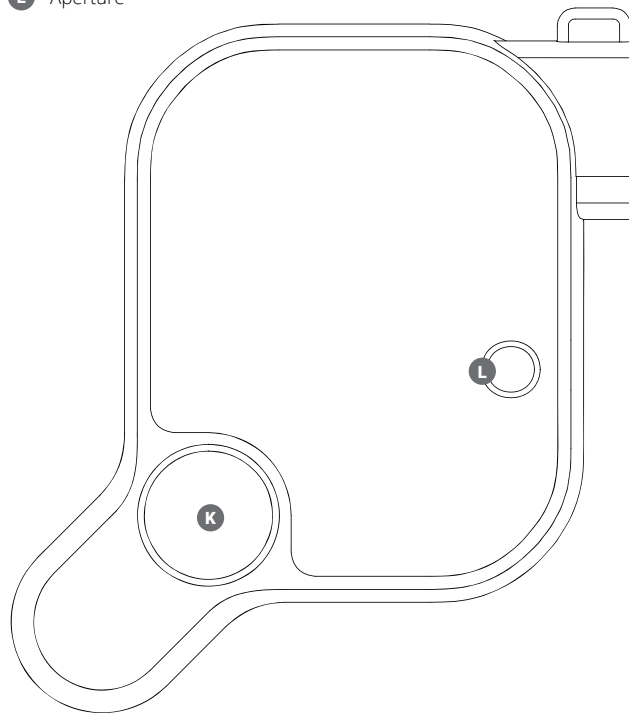

NETROPTER

Use

SETUP

- 1 Set the pupillary distance using the PD knob.



- 2 Pull the PD Lock into the UP position to lock in the PD.



- 3 Set the OD correction by adjusting the spherical and cylindrical error.

- I The Sphere Major Knob is the smaller knob, and it can be used to make adjustments in increments of 1.00D from -10D to +5D

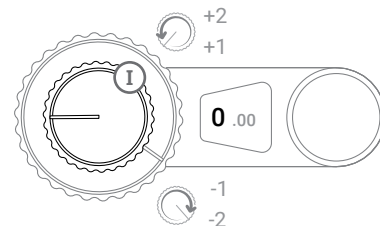

- II The Sphere Minor Knob is the larger knob, and it can be used to make adjustments in increments of 0.25D from 0D to -0.75D

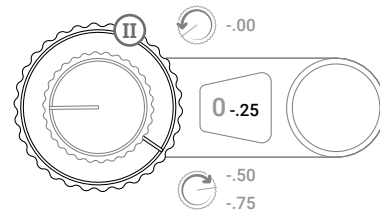

III

Set the cylindrical error using the Cylinder Knob.

IV

Set the axis using the Axis Knob.

Repeat for OS correction

4

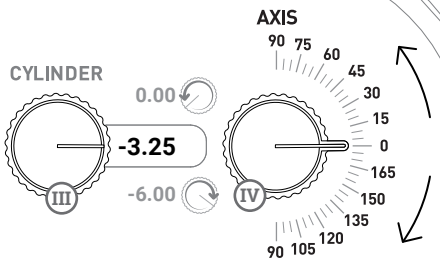

5

The Occluder switch can be used to open or close the aperture. To OPEN THE APERTURE, push the SWITCH DOWN.

THE OCCLUDER CAN BE USED FOR MONOCULAR TESTING

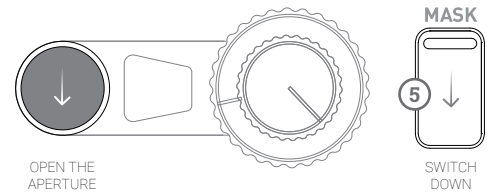

USE

- 1 When operating the NETROPTER, hold the device with knobs facing out.

USE INDOORS RATHER THAN IN DIRECT SUNLIGHT

- 2 Use both hands to grip the handles, with the thumbs resting in the recessed area.

USE INDOORS RATHER THAN IN DIRECT SUNLIGHT

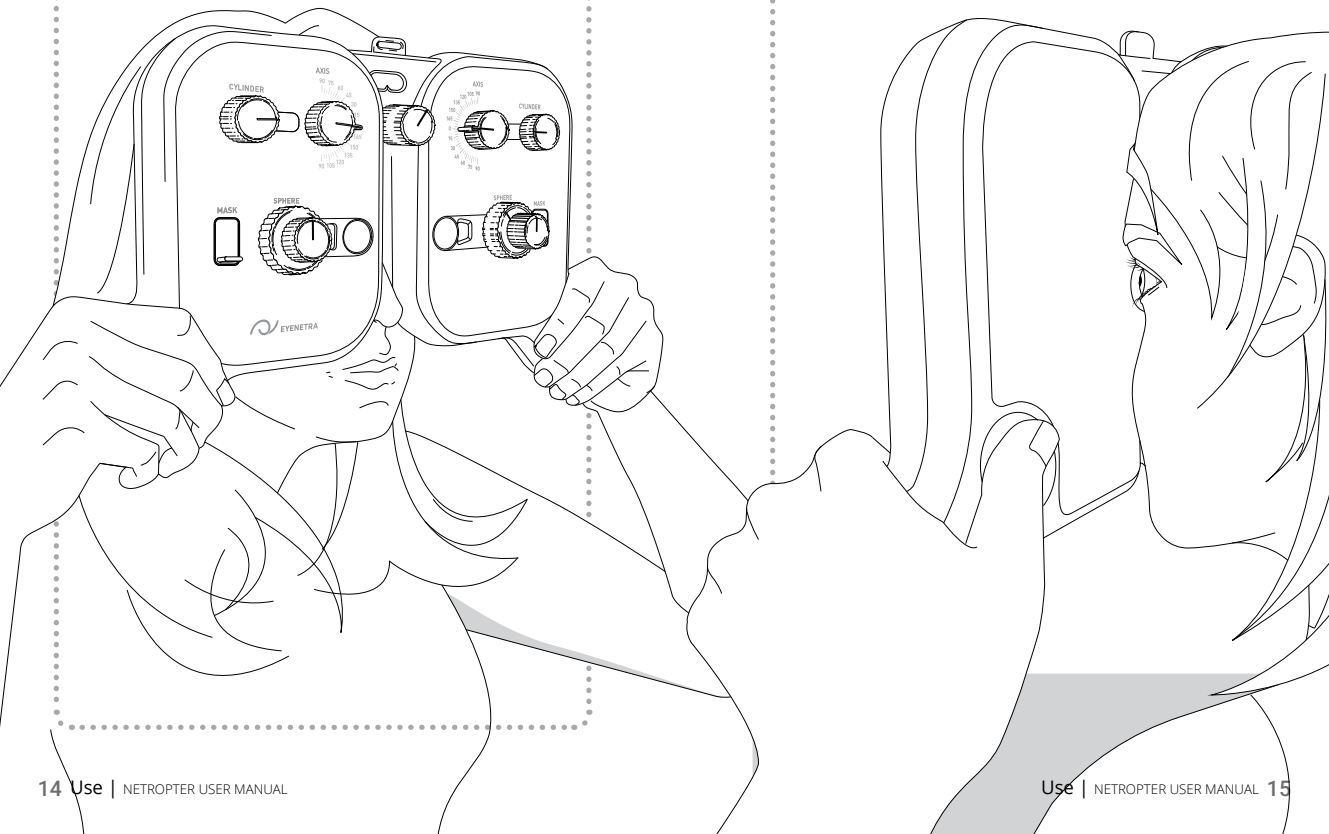

Rest the device against your forehead and look through the aperture(s).

3

NETROPTER CAN BE USED FOR BOTH "DISTANCE" AND "READING" VISUAL ACUITY TESTING

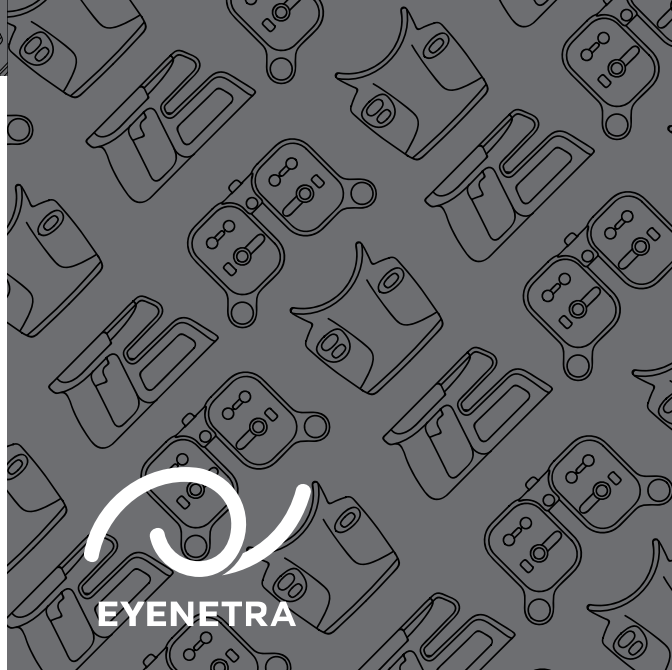
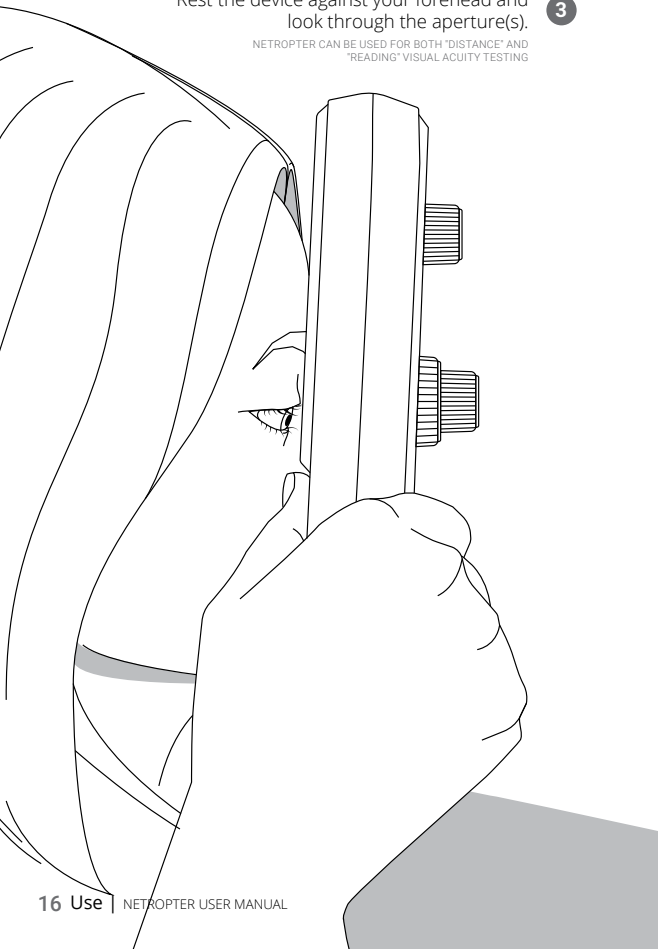

NETROPTER

Technical Specifications

TECHNOLOGY	TRIAL LENS STACK (25 LENSES PER EYE)
SPHERE RANGE	-10.75 to +5.0D, 0.25D increment
CYLINDRICAL RANGE	0 to -6D, 0.25D increment
AXIAL RANGE	0° to 180°, 1 degree increment
PUPILLARY DISTANCE RANGE	52 to 72mm, 1mm increment
VISUAL FIELD	~20° Degrees (14mm aperture)
ACUITY MEASUREMENTS	Binocular and Monocular
VISION TEST TYPE	Distance and Readers
DEVICE DIMENSIONS	5.0cm x 7cm x 10cm (less than 500g)
EXTERNAL PROCESSING UNIT	None
SETUP TIME	30 seconds
CALIBRATION REQUIREMENTS	None
POWER REQUIREMENTS	None (Manual Setup of Lenses)
SPECIALIZED FURNITURE REQUIREMENTS	None (Handheld)
FDA STATUS	Class I, exempt from 510(k) pre-market submission requirements
OPERATION	<ul style="list-style-type: none"> • Temperature: -15°C to 93°C • Relative humidity: 95% non-condensing
STORAGE/TRANSPORT	<ul style="list-style-type: none"> • Temperature: -15°C to 93°C • Relative humidity: 95% non-condensing

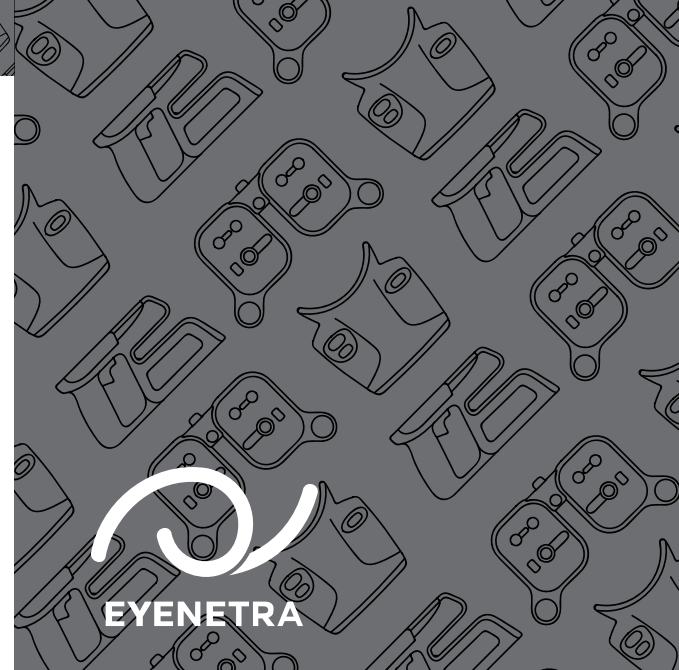

NETROPTER FAQ

DOES NETROPTER REQUIRE TRAINING?

NETROPTER's intuitive interface and great ease-of-use requires minimal training. The use is very similar to a conventional phoropter or lens kit. The more you use it, the more confident you will be with the process.

WHAT DIFFERENTIATES NETROPTER FROM OTHER EXISTING VISUAL ACUITY MEASUREMENT SYSTEMS?

NETROPTER is the world's first portable phoropter. It provides the ease of use, precision, and compact form factor of a phoropter with all of the portability of a trial lens kit. Unlike a trial lens kit, you can't lose individual lenses, mistakenly grab the wrong lens, or drop the kit and have to reorder 200 individual lenses.

DOES THE NETROPTER HAVE AUXILIARY LENSES (EG. PRISM LENSES, POLARIZED FILTERS OR RED-GREEN FILTERS, ETC.)?

Currently, NETROPTER only contains sphere and cylinder lenses.

IS THERE A VERSION OF THE NETROPTER FOR POSITIVE CYLINDER?

Currently, there is only one version of NETROPTER, which has negative cylinder lenses and labels.

IS IT NECESSARY TO LOCK THE PD IN ORDER TO RUN A VISUAL ACUITY TEST?

We recommend that the PD lock is engaged during testing to ensure that the patient doesn't accidentally change the PD while handling the NETROPTER.

CAN YOU REST YOUR ELBOWS ON A TABLE WHILE USING NETROPTER?

Yes, for users who are elderly, disabled, or for any reason unable to hold the Netropter in a stable manner, it is recommend to have the user rest their elbows on a stable surface while holding the Netropter for added comfort and stability.

CAN A SUBJECTIVE REFRACTION BE PERFORMED USING THE NETROPTER?

Yes! Any qualified person can perform a standard subjective refraction using the Netropter by adjusting the knobs while the user is looking through the Netropter.

DOES NETROPTER DO A FULL EYE HEALTH EXAM?

Caution 1 - No, NETROPTER is not an intended substitute for a full eye health exam. EyeNetra encourages you to consult with your optometrist or ophthalmologist.

Caution 2 - NETROPTER does not measure any higher-order aberrations or quantify retinal conditions.

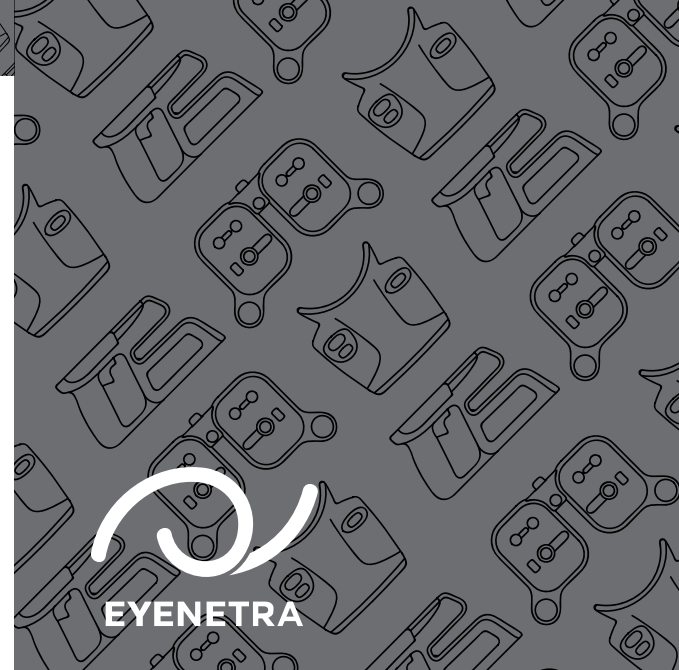

NETROPTER

Warranty and Support

All Eyenetra devices are guaranteed for 1-year from date of purchase. If you purchased directly from Eyenetra, please contact customer service by calling **Monday** thru **Friday** 9:00 AM - 5:00 PM (EST) +1 (857) 997 2057 or by visiting our customer support website at store.eyenetra.com with any issues. If you purchased from an authorized re-seller, please contact them directly.

LIMITED WARRANTY - HARDWARE

This warranty applies only to mechanical devices: NETRA, NETROMETER, and NETROPTER, referred to as (the PRODUCT). For software warranty please see the Limited Warranty - Software

A. LIMITED WARRANTY

Eyenetra, Inc. (Eyenetra) warrants to the original purchaser that the PRODUCT will be free from defects in material and workmanship for a period of one year from the date of delivery. Eyenetra does not warrant that operation of the PRODUCT will be error-free or uninterrupted. If the PRODUCT is found to be defective during the warranty period, the part(s) and labor required to repair the PRODUCT will be provided by Eyenetra free of charge. To receive warranty repair the PRODUCT must be returned to Eyenetra. This warranty is subject to the following exceptions and limitations:

- The customer shall be responsible for proper maintenance and handling of the PRODUCT.
- No warranty is extended to any PRODUCT that has been altered or modified in any way.
- No warranty is extended to any PRODUCT that has been misused, or damaged.

B. TERM OF WARRANTY

This limited warranty covers the PRODUCT for one year from the date of delivery. If you receive supplements, updates, or replacement PRODUCT during that year, they will be covered for the remainder of the warranty or 30 days, whichever is longer.

C. EXCLUSIONS FROM WARRANTY

This warranty does not cover problems caused by your acts (or failures to act), the acts of others, or events beyond Eyenetra's reasonable control.

D. NO OTHER WARRANTIES

This limited warranty is the only warranty from Eyenetra. Eyenetra gives no other express warranties, guarantees or conditions. Where allowed by your

local laws, Eyenetra excludes implied warranties of merchantability, fitness for a particular purpose and non-infringement.

E. REMEDY FOR BREACH OF WARRANTY

If Eyenetra cannot repair a defective PRODUCT, Eyenetra will replace the PRODUCT or refund the amount shown on the invoice for the PRODUCT. To receive a refund you must return the PRODUCT and other associated materials to Eyenetra. This is your only remedy for breach of this limited warranty.

F. CONSUMER RIGHTS NOT AFFECTED

You may have additional consumer rights under your local laws that this agreement cannot change.

G. NO LIABILITY

In no event shall Eyenetra be liable for any damages (including, without limitation, lost profits, business interruption, or lost information) arising out of your use of or inability to use the PRODUCT, even if Eyenetra has been advised of the possibility of such damages. No distributor, dealer or other party is authorized to make any warranty on behalf of Eyenetra, or to assume for Eyenetra any other liability with respect to its PRODUCTS.

LIMITED WARRANTY - SOFTWARE

This warranty applies only to software applications and firmware (the SOFTWARE). For hardware warranty please see the Limited Warranty - Hardware

A. LIMITED WARRANTY

Eyenetra, Inc. (Eyenetra) warrants that if you follow the instructions, the SOFTWARE will perform substantially as described in the Eyenetra materials that you receive in or with the SOFTWARE. Eyenetra does not warrant that the operation of the SOFTWARE will be error-free or uninterrupted. If the SOFTWARE is defective Eyenetra will repair or replace the SOFTWARE free of charge. This warranty is subject to the following exceptions and limitations:

- No warranty is extended to any SOFTWARE that is being used on unsupported operating systems and/or computer hardware.
- No warranty is extended to any SOFTWARE that has been altered or modified in any way.
- No warranty is extended to any SOFTWARE that is being used on a system that has been corrupted by computer viruses, spy ware, or any third party software or device.

B. TERM OF WARRANTY

This limited warranty covers the SOFTWARE for one year from the date of delivery. If you receive supplements, updates, or replacement SOFTWARE during that year, they will be covered for the remainder of the warranty or 30 days, whichever is longer.

C. EXCLUSIONS FROM WARRANTY

This warranty does not cover problems caused by your acts (or failures to act), the acts of others, or events beyond Eyenetra' reasonable control.

D. NO OTHER WARRANTIES

This limited warranty is the only warranty from Eyenetra. Eyenetra gives no other express warranties, guarantees or conditions. Where allowed by your local laws, Eyenetra excludes implied warranties of merchantability, fitness for a particular purpose and non-infringement.

E. REMEDY FOR BREACH OF WARRANTY

If Eyenetra cannot repair the defective SOFTWARE Eyenetra will replace the SOFTWARE through a reinstallation process. This is your only remedy for breach of this limited warranty.

F. CONSUMER RIGHTS NOT AFFECTED

You may have additional consumer rights under your local laws that this agreement cannot change.

G. NO LIABILITY

In no event shall Eyenetra be liable for any damages (including, without limitation, lost profits, business interruption, or lost information) arising out of your use of or inability to use the SOFTWARE, even if Eyenetra has been advised of the possibility of such damages. No distributor, dealer or other party is authorized to make any warranty on behalf of Eyenetra, or to assume for Eyenetra any other liability with respect to its SOFTWARE.

CHANGING THESE TERMS

Eyenetra, Inc. may change these terms by posting notice on its website. Warranty and Support Statement Last Updated: August 7, 2015.

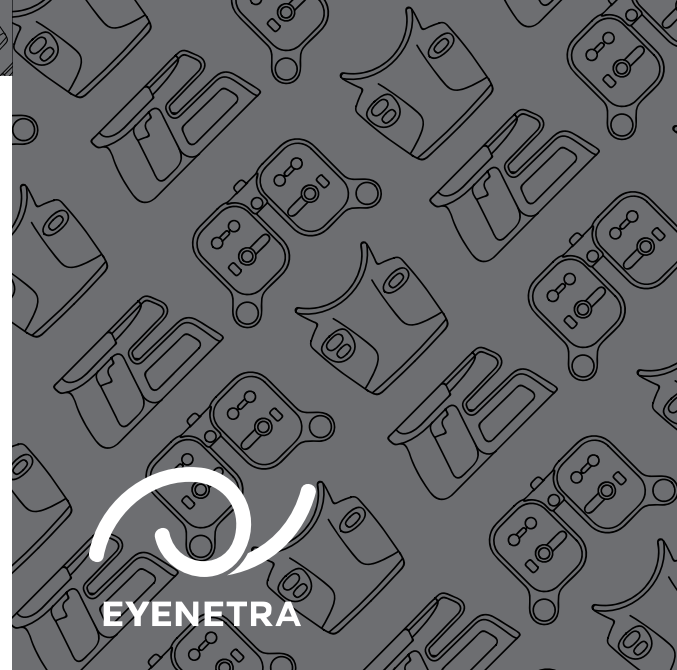

NETROPTER Terms of Sale

TERMS OF SALE ---- PLEASE READ CAREFULLY: THE FOLLOWING TERMS WILL GOVERN PURCHASES MADE VIA THE EYENETRA STORE (STORE.EYENETRA.COM). BY USING, PURCHASING AN EYENETRA PRODUCT OR SERVICE, OR BY CHOOSING THE "I ACCEPT" OPTION LOCATED ON OR ADJACENT TO THE SCREEN WHERE THESE TERMS MAY BE DISPLAYED, YOU AGREE TO THE TERMS BELOW. IF YOU ARE ACCEPTING THESE TERMS ON BEHALF OF ANOTHER PERSON OR A COMPANY OR OTHER LEGAL ENTITY, YOU REPRESENT AND WARRANT THAT YOU HAVE FULL AUTHORITY TO BIND THAT PERSON, COMPANY, OR LEGAL ENTITY TO THESE TERMS. IF YOU DO NOT AGREE TO THESE TERMS, DO NOT PURCHASE EYENETRA PRODUCTS OR SERVICES.

1. Parties. These terms represent the agreement ("Agreement") that governs the purchase of products and services from Eyenetra, Inc. ("Eyenetra") by the individual or entity purchasing products or services from Eyenetra ("Customer").
2. Application. These terms apply to products, including without limitation, the NETROMETER, NETRA, and NETROPTER ("Eyenetra Products"), software included in Eyenetra Products ("Eyenetra Software"), and services ("Eyenetra Services") made available for sale from Eyenetra via the Eyenetra Store.
3. Orders. "Order" means an order placed by a Customer that has been accepted by Eyenetra, including any supporting material which the parties identify as incorporated either by attachment or reference ("Supporting Material"). Supporting Material may include (as examples) product lists, hardware or software specifications, standard or negotiated service descriptions, data sheets and their supplements, and statements of work (SOWs), published warranties and service level agreements, and may be available to Customer in hard copy or by accessing the Eyenetra Store.
4. Prices and Taxes. Prices will be as quoted as set out on the Eyenetra Store website at the time an Order is submitted to Eyenetra and accepted. Prices are exclusive of taxes, duties, and fees (including installation, shipping, and handling) unless otherwise quoted.
5. Payment. Payment is due as specified in the Eyenetra web-site in U.S. Dollars. Eyenetra may suspend or cancel performance of open Orders or Eyenetra Services if Customer fails to make payments when due.
6. Title. Except as provided herein, title and risk of loss to Eyenetra Products will pass on shipment to Customer. Eyenetra Software: (1) is owned or licensed by Eyenetra; (2) is proprietary to Eyenetra and its licensors; and (3) constitutes trade secrets of Eyenetra and its licensors.
7. Delivery. Eyenetra will use commercially reasonable effort to deliver products in a timely manner. Eyenetra anticipates first delivery of Eyenetra products will take place in February of 2016.

8. Services. Eyenetra Services, including without limitation, support services will be described in the applicable Supporting Materials and Statements of Work, which will cover the description of Eyenetra's offering, eligibility requirements, service limitations and Customer responsibilities, as well as the Eyenetra Products supported.
9. Eligibility. Eyenetra's service, support and warranty commitments do not cover claims resulting from: (a) improper use, environmental conditions or non-compliance with applicable Supporting Material; (b) modifications or improper system maintenance or calibration not performed by Eyenetra or authorized by Eyenetra; (c) malware (e.g. virus, worm, etc.) not introduced by Eyenetra; or (d) abuse, negligence, accident, fire or water damage, electrical disturbances, transportation by Customer, or other causes beyond Eyenetra's control.
10. Client Cooperation. Eyenetra's ability to deliver Eyenetra Products and services will depend on Customer's reasonable and timely cooperation and the accuracy and completeness of any information from Customer.
11. Product Performance. All Eyenetra Products are covered by Eyenetra's limited warranty statements that are provided with the products or otherwise made available on the Eyenetra Store web-site. All Eyenetra warranties begin on the date of delivery.
12. Services Performance. Services are performed using generally recognized commercial practices and standards. Customer agrees to provide prompt notice of any such service concerns and Eyenetra will re-perform any service that fails to meet this standard.
13. Intellectual Property Rights. Except as provided herein, no transfer of intellectual property will take place upon the sale of any Eyenetra Products.
14. License Grant. Eyenetra grants Customer a non-exclusive license to use the version or release of the Eyenetra Software included in Eyenetra Products included in an Order. Permitted use is for internal purposes only (and not for further commercialization). Customer agrees that it will also not copy, modify, reverse engineer, disassemble, decrypt, decompile or make derivative works of any Eyenetra Software licensed to Customer under this Agreement unless permitted by statute, in which case Customer will provide Eyenetra with reasonably detailed information about those activities. Unless otherwise specified, any license granted is perpetual, provided however that if Customer fails to comply with the terms of this Agreement, EyeNeta may terminate the license upon written notice. Immediately upon termination, Customer will either destroy all copies of the software or return them to Eyenetra.
15. Intellectual Property Rights Infringement. Eyenetra will defend and/or settle any claims against Customer that allege that an Eyenetra Product or service as supplied under this Agreement infringes the

intellectual property rights of a third party. Eyenetra's obligations under this paragraph are conditioned upon Customer's prompt notification of the claim and cooperation with our defense. Eyenetra may modify the product or service so as to be non-infringing and materially equivalent, or may procure a license. If these options are not available, Eyenetra will refund to Customer the amount paid for the affected product in the first year or the depreciated value thereafter or, for support services, the balance of any pre-paid amount. Eyenetra is not responsible for claims resulting from any unauthorized use of Eyenetra Products or services. This paragraph constitutes Customer's sole remedy for a claim of intellectual property rights infringement.

16. Updates. Eyenetra may make new software versions, releases or maintenance updates ("Updates"). Additional licenses or fees may apply for these Updates. Updates are subject to the license terms in effect at the time that Eyenetra makes them available to Customer.
17. Compliance. The Customer is responsible for complying with all local laws and regulations with respect to the purchase and use of EyeNetra's products.
18. Force Majeure. Neither party will be liable for performance delays nor for non-performance due to causes beyond its reasonable control, except for payment obligations.
19. Termination. Either party may terminate this Agreement on written notice if the other fails to meet any material obligation and fails to remedy the breach within a reasonable period after being notified in writing of the details. If either party becomes insolvent, unable to pay debts when due, files for or is subject to bankruptcy or receivership or asset assignment, the other party may terminate this Agreement and cancel any unfulfilled obligations. Any terms in the Agreement which by their nature extend beyond termination or expiration of the Agreement will remain in effect until fulfilled and will apply to both parties' respective successors and permitted assigns.
20. General. This Agreement, along with Eyenetra's Terms of Sale and other documents referenced herein, represent our entire understanding with respect to its subject matter and supersedes any previous communication or agreements that may exist. Modifications to the Agreement will be made only through a written amendment signed by both parties. The Agreement will be governed by the laws Commonwealth of Massachusetts, without regard to conflicts of laws provisions, and the courts of that locale will have jurisdiction. Customer and Eyenetra agree that the United Nations Convention on Contracts for the International Sale of Goods will not apply. This Agreement shall be binding on each party's successors and assigns.



NETROPTER

Refund Policy



RETURNS

Our policy is 10 days risk-free. You have 10 days from the date of receipt to use and return the product to be eligible for a refund.

To be eligible for a return, your item must be in excellent condition (the same condition that you received it.) It must also be in the original packaging.

There are certain situations where only partial refunds are granted. For example, if an item is not in its original condition, is damaged, or is missing parts for reasons not due to EyeNetra's error, then partial refunds may be granted.

REFUNDS (IF APPLICABLE)

Once your return is received and inspected, we will send you an email to notify you that we have received your returned item. We will also notify you of the approval or rejection of your refund. If you are approved, then your refund will be processed, and a credit will automatically be applied to your credit card or original method of payment, within a certain amount of days.

LATE OR MISSING REFUNDS (IF APPLICABLE)

If you haven't received a refund yet, first check your bank account. Then, contact your credit card company or bank, it may take some time before your refund is officially posted. There is often some processing time before a refund is posted. If you've done all of this and you still have not received your refund yet, please contact us at info@eyenetra.com.

EXCHANGES UNDER WARRANTY

Please refer to the Warranty and Support section of this user manual for detailed instructions.

SHIPPING

If you purchased your product directly from EyeNetra, you should mail your product to: 35 Medford St., Suite #302, Somerville Massachusetts USA 02143. You will be responsible for paying for your own shipping costs for returning your item. Shipping costs are non-refundable. If you receive a refund, the cost of return shipping will be deducted from your refund.

If you purchased your product from an authorized reseller, please contact them directly for detailed shipping instructions.

Depending on where you live, the time it may take for your exchanged product to reach you, may vary.

You should consider using a trackable shipping service or purchasing shipping insurance. We don't guarantee that we will receive your returned item.

NETROPTER USER MANUAL

DIGITAL VERSION

<http://www.eyenetra.com/manual/netropter.pdf>



EYENETRA

	<table border="1"><tr><td>REF</td></tr></table>	REF	NETROPTER v1.01	<table border="1"><tr><td>EC</td><td>REP</td></tr></table>	EC	REP
REF						
EC	REP					
						
6	88713	04875	7			
			 Emergo Molenstraat 15 2513 BH, The Hague The Netherlands EyeNetra 35 Medford St. #302 Somerville, MA 02143 USA			

05/26/2016 | Version 1.0
Printed in the USA